

6.1- UNIT SPECIFICATIONS

6A- WINDOW SILL - SPLIT FACE

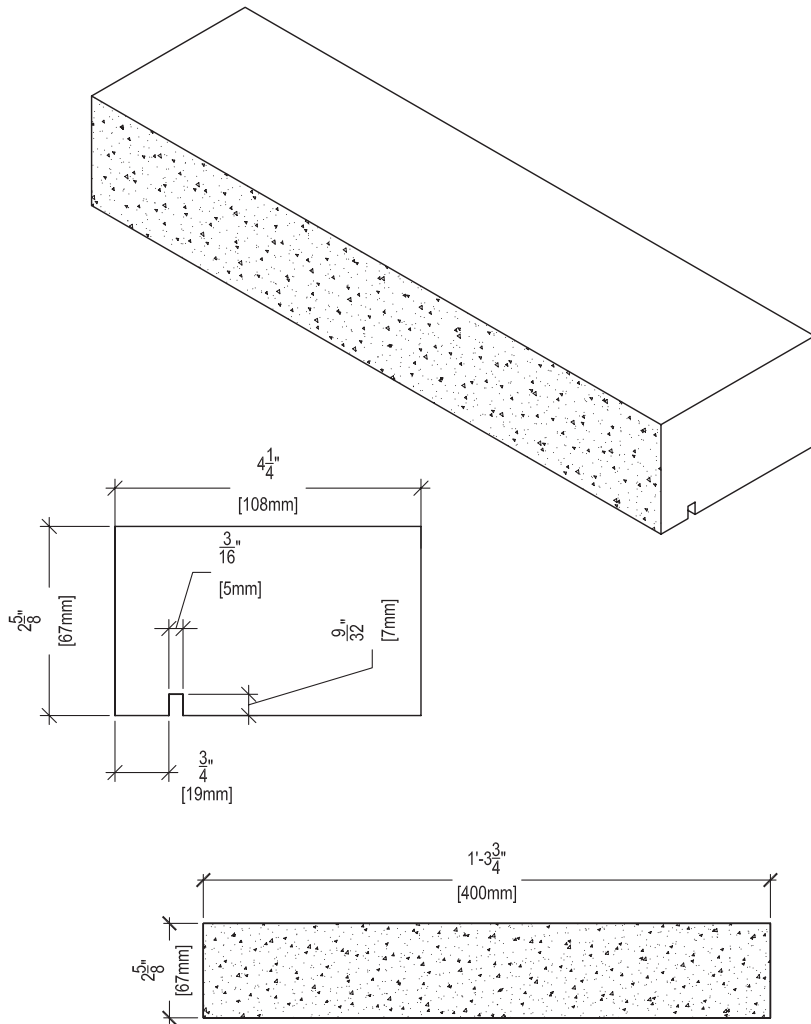

SPECIFICATIONS

LENGTH: $15\frac{3}{4}$ " (400MM)

SIZE: $2\frac{1}{4}$ " x $4\frac{1}{2}$ " (58MM x 108MM)

FACE HEIGHT: $2\frac{1}{4}$ " (58MM)

WEIGHT: 19.1 LBS / BRICK OR 9.7 LBS / LN.FT.
 8.7 KG / BRICK OR 13.9 KG / LN.M

COVERAGE: 0.5 BRICKS / LN. FT. (1.6 BRICKS / LN.M)

MATERIAL: CONCRETE

COMPRESSIVE STRENGTH: 3600 PSI (25 MPA)

MAXIMUM WATER ABSORPTION: 4 TO 5%