

6.1- UNIT SPECIFICATIONS

4B- 90° INTERIOR CORNER BLOCK - SMOOTH FACE

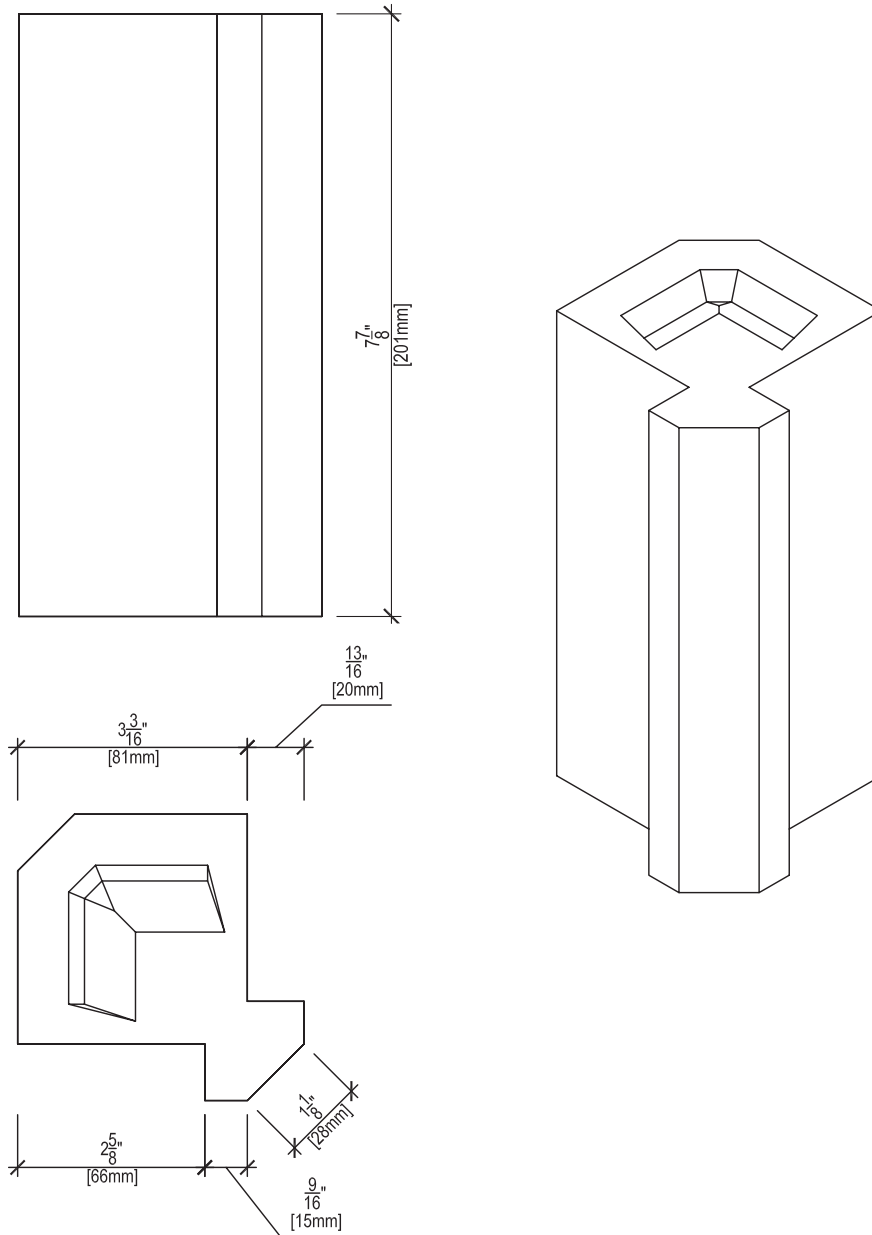

SPECIFICATIONS

SPLIT FACE LENGTH: 1 1/8" (28MM)

MATERIAL: CONCRETE

SPLIT FACE HEIGHT: 7 7/8" (200MM)

COMPRESSIVE STRENGTH: 3600 PSI (25 MPA)

WEIGHT: 8.9 LBS / BRICK OR 13.4 LBS / LN.FT.
 4.1 KG / BRICK OR 20.5 KG / LN.M

MAXIMUM WATER ABSORPTION: 4 TO 5%

COVERAGE: 1.5 BRICKS / LN. FT. (5 BRICKS / LN.M)