

## 6.1- UNIT SPECIFICATIONS

### 2B- 90° EXTERIOR CORNER BLOCK - SMOOTH FACE

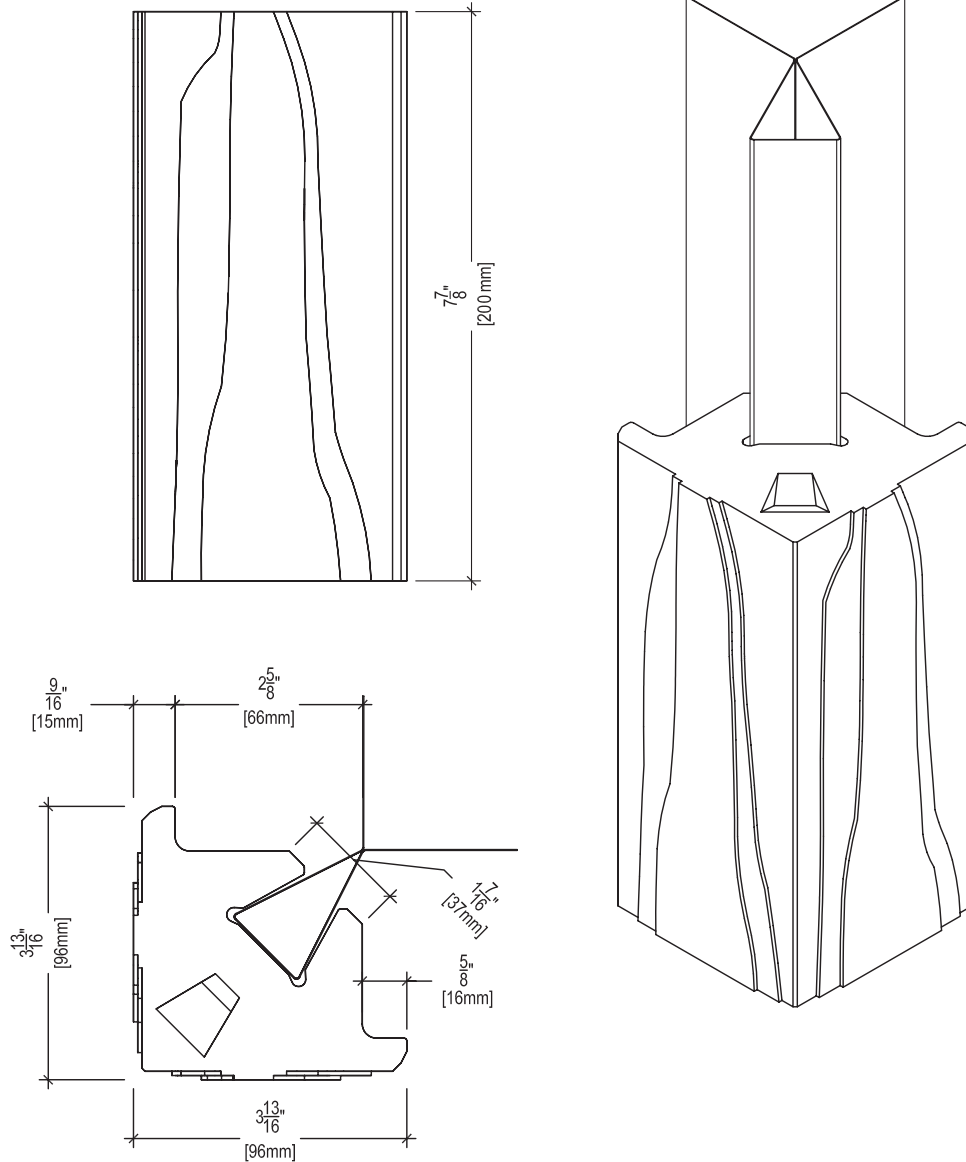

---

#### SPECIFICATIONS

---

FACE LENGTH: 3 13/16" (96MM)

FACE HEIGHT: 7 7/8" (200MM)

WEIGHT: 5.9 LBS / BRICK      OR      8.8 LBS / LN.FT.  
                  2.7 KG / BRICK      OR      13.2 KG / LN.M

COVERAGE: 1.5 BRICKS / LN. FT. (5 BRICKS / LN.M)

MATERIAL: CONCRETE

COMPRESSIVE STRENGTH: 3600 PSI (25 MPA)

MAXIMUM WATER ABSORPTION: 4 TO 5%