

6.1- UNIT SPECIFICATIONS

1A- NOVABRIK 4" - SPLIT FACE

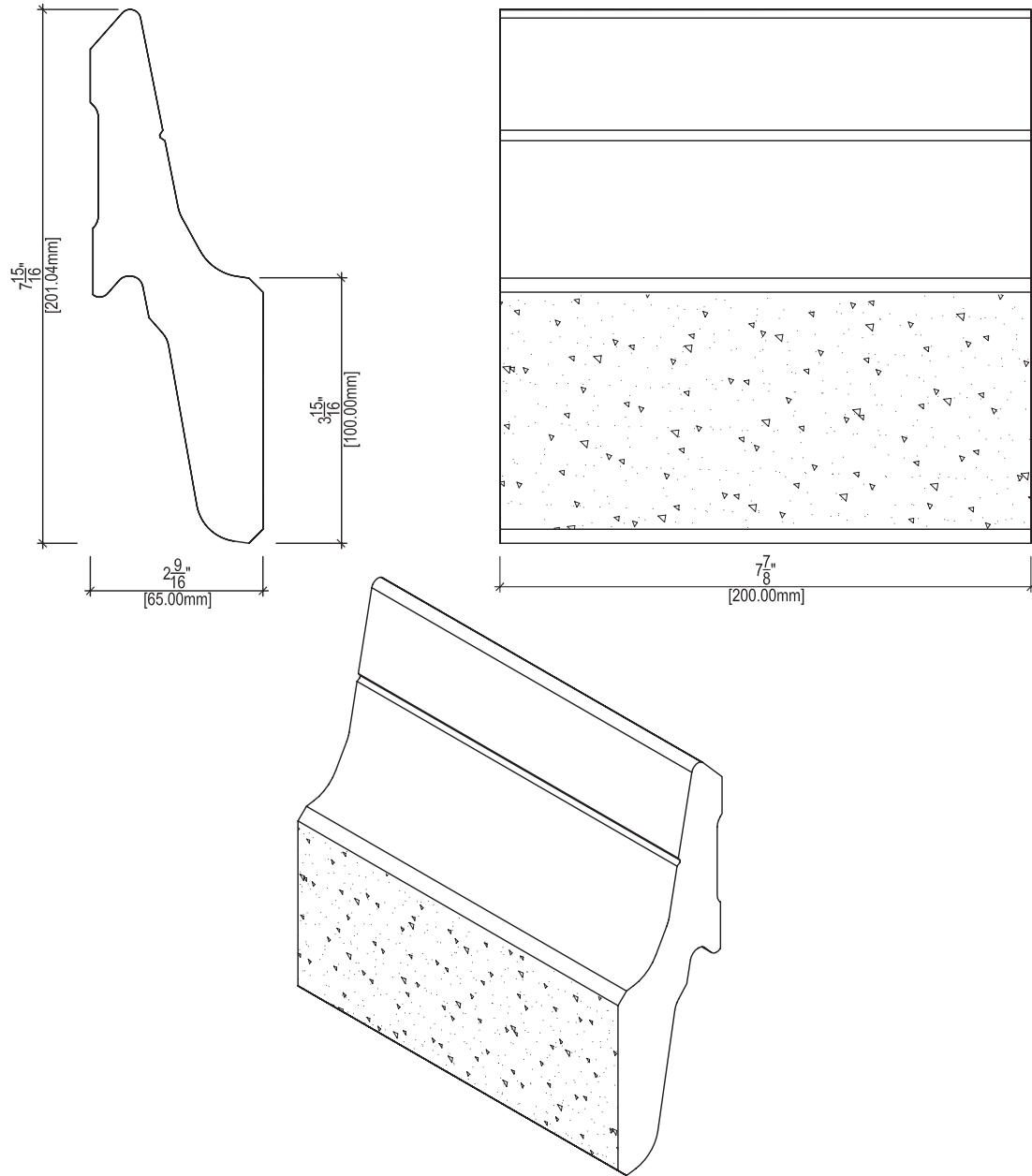

SPECIFICATIONS

LENGTH: 7 7/8" (200MM)

HEIGHT: 7 15/16" (201MM)

FACE HEIGHT: 3 15/16" (100MM)

WEIGHT: 5.3 LBS / BRICK OR 25 LBS / SQ.FT.
 2.4 KG / BRICK OR 120 KG / SQ.M

COVERAGE: 4.5 BRICKS / SQ. FT. (50 BRICKS / SQ.M)

MATERIAL: CONCRETE

COMPRESSIVE STRENGTH: 3600 PSI (25 MPA)

MAXIMUM WATER ABSORPTION: 4 TO 5%